

INLET:
 FX=150 LBF[667 N] FY=150 LBF[667 N] FZ=150 LBF[667 N]
 MX=250 LB FT[339 N·m] MY=250 LB FT[339 N·m] MZ=250 LB FT[339 N·m]

OUTLET:
 FX=113 LBF[500 N] FY=113 LBF[500 N] FZ=113 LBF[500 N]
 MX=188 LB FT[254 N·m] MY=188 LB FT[254 N·m] MZ=188 LB FT[254 N·m]

FORCE AND MOMENT VALUES ARE RELATIVE TO CENTER OF INLET AND OUTLET PORT FACES.

REVISION HISTORY						
CHG NO	ZONE	REV	DESCRIPTION	DATE	BY	APPROVED
01-0492	ALL	1	ADDED DIMENSIONS FOR VERTICAL MOUNTING USING BRACKET ADAPTER MOUNTING HOLES & ADDED NOTE CONCERNING MOTOR FLANGE DIAMETERS	10-16-01	DMM	DMM

ITEM	DESCRIPTION	APPROXIMATE WEIGHT		MATERIAL
		LBS	KG	
1	MOTOR (254TC & 256TC)	298.0	135.1	
2	PUMP	44.0	20.0	
3	COUPLING, LOVEJOY L-110	6.0	2.7	
4	BRACKET	5.0	2.3	ALUMINUM
5	BRACKET ADAPTER	1.0	0.5	ALUMINUM
TOTAL		354.0	160.6	

DRIVER DIMENSIONS MAY VARY WITH TYPE AND MAKE OF DRIVER. THE MOTOR MOUNTING FLANGE DIAMETER VARIES SIGNIFICANTLY FOR SOME MANUFACTURERS WHICH CAN PREVENT THE USE OF THE VERTICAL MOUNTING HOLES IN THE ADAPTER PLATE. CHECK THE MOTOR MANUFACTURER DIMENSIONS TO MAKE SURE THE MOTOR FLANGE DIAMETER (BD) DOES NOT EXCEED 9 1/2" IF USING BRACKET MOUNTING.

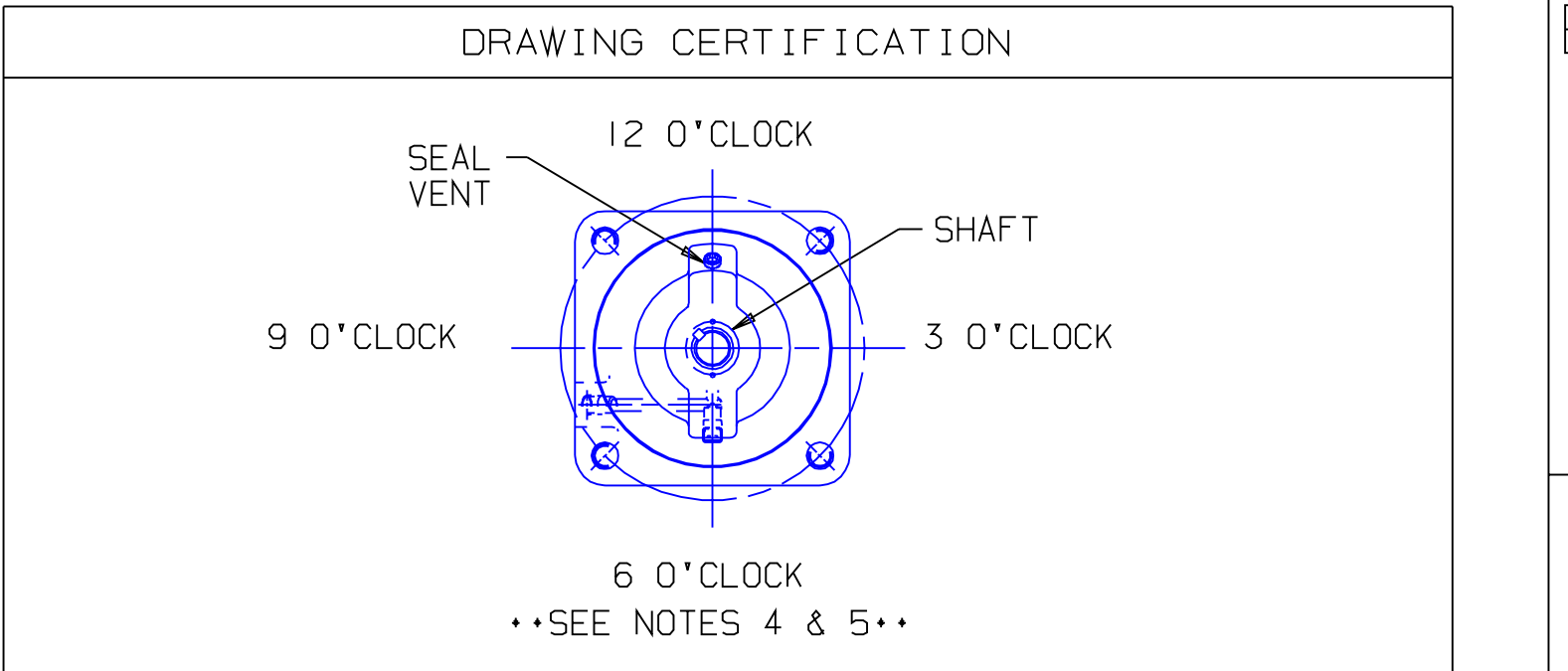
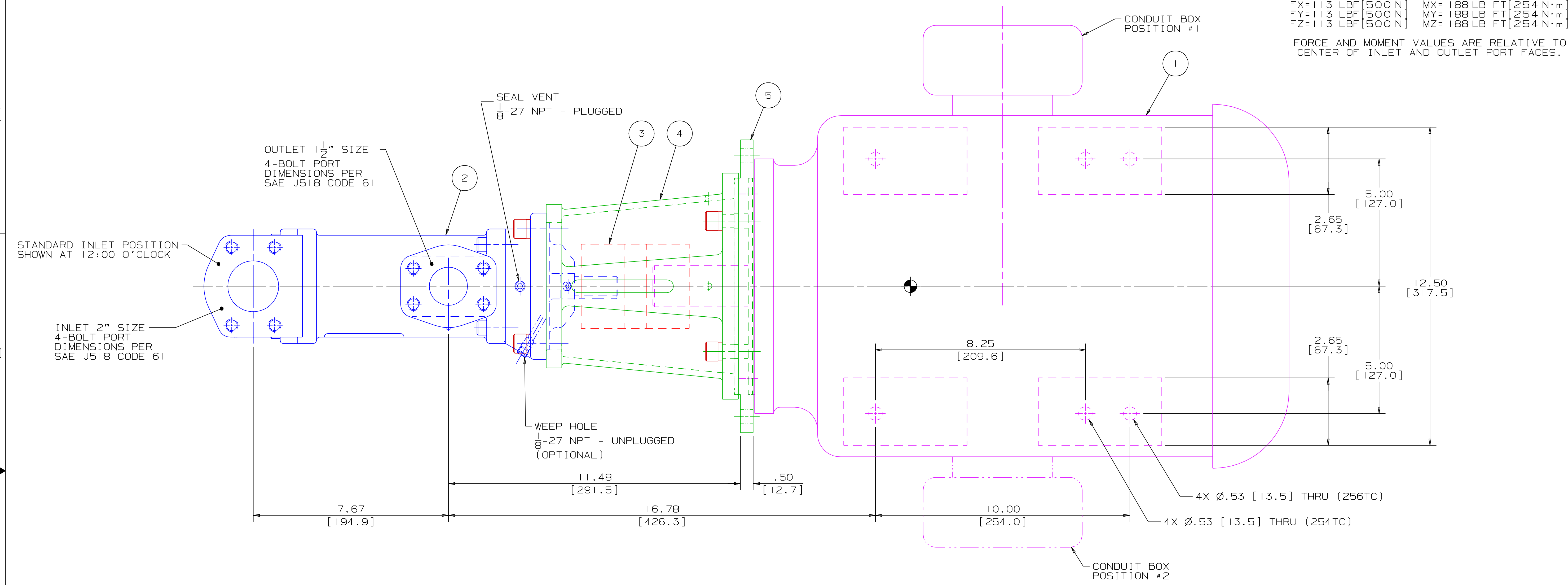

CUSTOMER NAME -----

CUSTOMER PO NUMBER -----

CUSTOMER PART NUMBER -----

UNIT BOM NUMBER -----

PUMP TYPE -----

SHAFT ROTATION -----

INLET PORT ORIENTATION -----

OUTLET PORT ORIENTATION -----

INLET ADAPTER OPTION -----

OUTLET ADAPTER OPTION -----

MOTOR MANUFACTURER -----

TYPE -----

FRAME -----

POWER -----

ROTATING SPEED -----

PHASE(S) -----

FREQUENCY -----

VOLTAGE -----

CONDUIT BOX POSITION -----

MOTOR INSTALLED BY -----

CERTIFIED BY -----

IMO ORDER NUMBER -----

CERTIFICATION DATE -----

CERTIFICATION REV. NO. -----

NOTES:

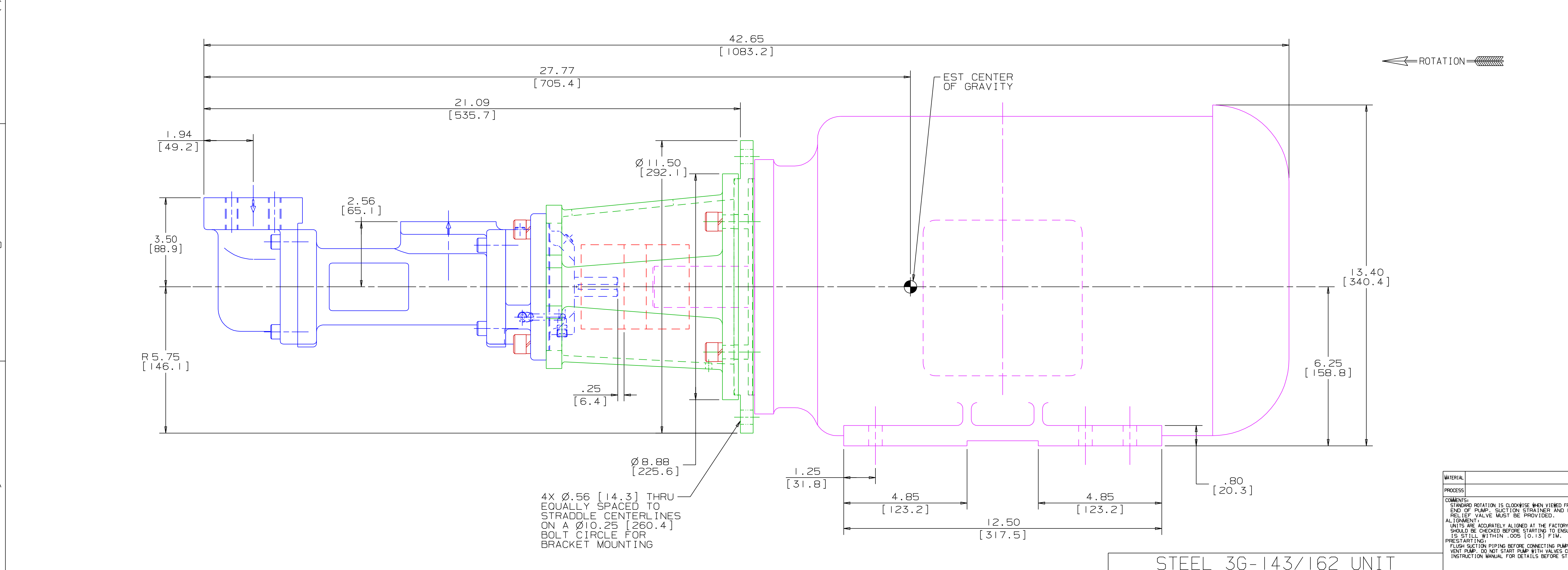

NOTES:

- UNLESS OTHERWISE SPECIFIED, ALL DIMENSIONS ARE IN INCHES. DIMENSIONS IN [] ARE MILLIMETERS.
- THIS IS A STANDARD PRE-ENGINEERED UNIT OUTLINE. ANY CHANGES OUTSIDE OF THE CERTIFICATION BLOCK WILL REQUIRE A NEW DRAWING ASSIGNMENT.
- APPROXIMATE WEIGHT AND ESTIMATED C/G DO NOT INCLUDE OPTIONAL ADAPTERS OR OPTIONAL RELIEF VALVE.
- TO MAXIMIZE SEAL LIFE, SEAL VENT MUST BE ORIENTED UPWARD (12 O'CLOCK) WHEN PUMP IS INSTALLED HORIZONTALLY. VENT ORIENTATION IS NOT CRITICAL WHEN PUMP IS INSTALLED WITH SHAFT VERTICALLY UPWARD.
- ALTERNATE PORT ORIENTATIONS ARE PROVIDED IF SPECIFIED ON ORDER. AVAILABLE ORIENTATIONS ARE 3,6,9, AND 12 O'CLOCK.

WEB ADDRESS: WWW. IMO-PUMP.COM EMAIL: IMO.PUMP@COLFAXCORP.COM

DRAWN	DMM	8-20-01
CHECKED	DMM	9-25-01
APPD	DMM	9-25-01
PROCESS		

Imo Pump
 1710 Airport Road
 PO Box 5020
 Monroe, NC USA
 28111.5020

TITLE: OUTLINE UNIT STANDARD (STEEL)
 AA3G / - - S - - 143 / 162 - -

SIZE: SDD20240
 CAGE CODE: 59180
 DWG NO: SDD20240

SCALE: 1/2 WEIGHT: SEE ABOVE SHEET 1 OF 1

STEEL 3G-143/162 UNIT