

INLET:
 FX=113 LBF [500 N] MX=188 LB FT [254 N·m]
 FY=113 LBF [500 N] MY=188 LB FT [254 N·m]
 FZ=113 LBF [500 N] MZ=188 LB FT [254 N·m]

OUTLET:
 FX=75 LBF [334 N] MX=125 LB FT [169 N·m]
 FY=75 LBF [334 N] MY=125 LB FT [169 N·m]
 FZ=75 LBF [334 N] MZ=125 LB FT [169 N·m]

FORCE AND MOMENT VALUES ARE RELATIVE TO CENTER OF INLET AND OUTLET PORT FACES.

REVISION HISTORY					
CHG NO	ZONE	REV	DESCRIPTION	DATE	BY / APPROVED
01-0503	A2,D2	1	REMOVED NOTE 6 & REVISED CERTIFICATION BLOCK	10-17-01	DMM / DMM

ITEM	DESCRIPTION	APPROXIMATE WEIGHT		MATERIAL
		LBS	KG	
1	MOTOR * (143TC & 145TC)	68.0	30.8	
2	PUMP	34.0	15.4	
3	COUPLING, LOVEJOY L-110	6.0	2.7	
4	BRACKET	2.2	1.0	ALUMINIUM
5	BRACKET ADAPTER	1.0	0.5	ALUMINIUM
TOTAL		111.2	50.4	

* DRIVER DIMENSIONS MAY VARY WITH TYPE AND MAKE OF DRIVER

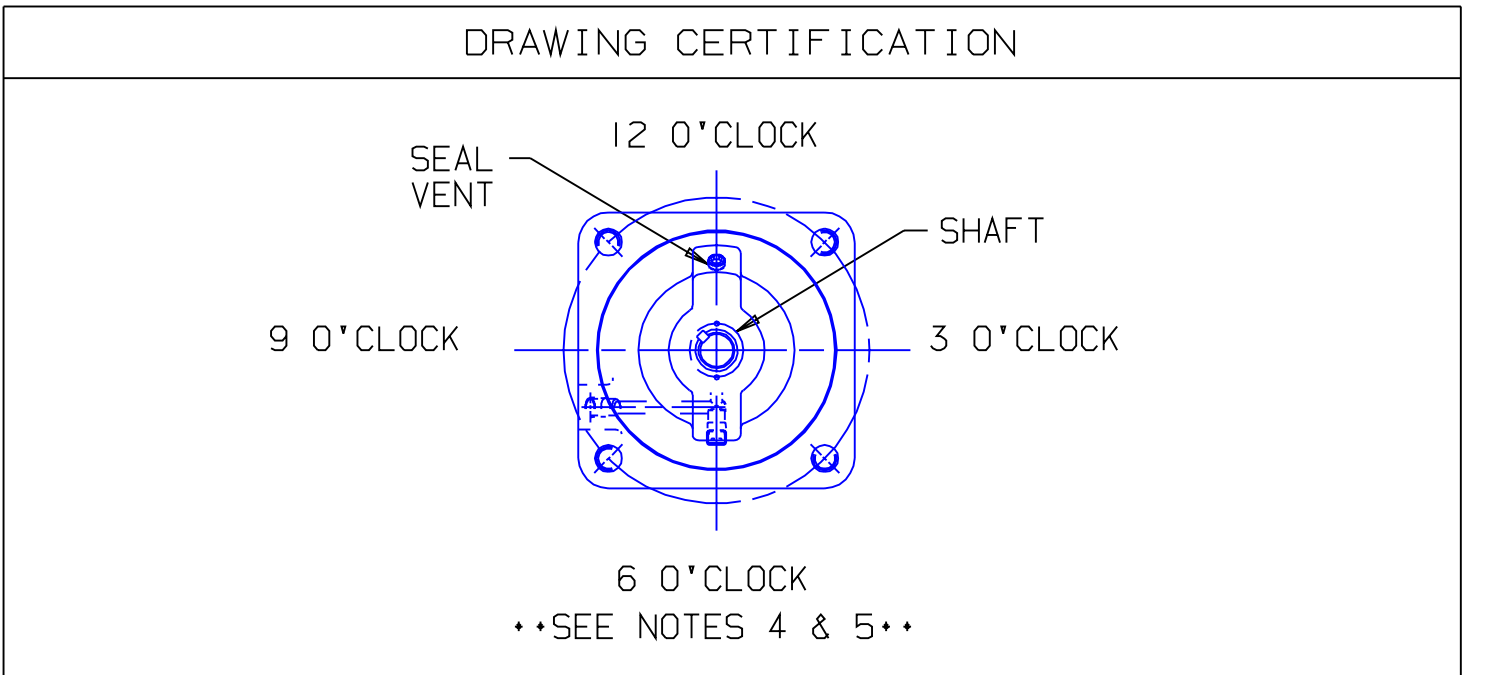
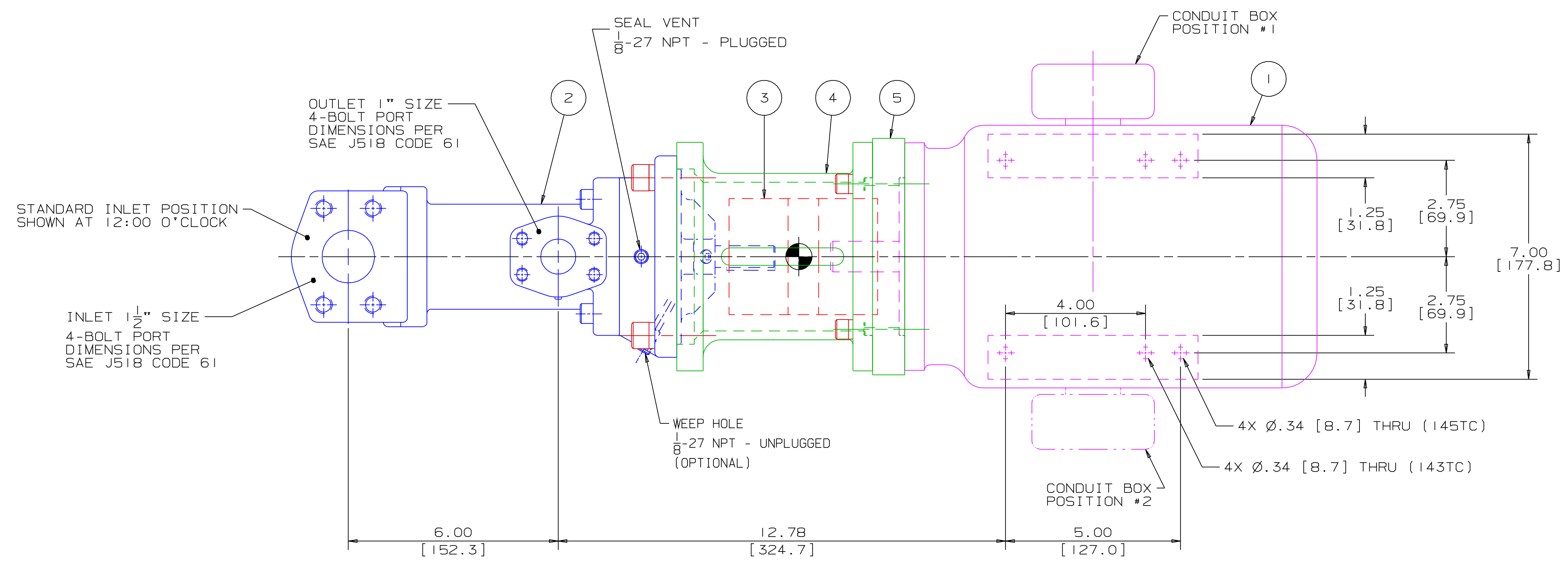

CUSTOMER NAME -----

CUSTOMER PO NUMBER -----

CUSTOMER PART NUMBER -----

UNIT BOM NUMBER -----

PUMP
 PUMP TYPE -----
 SHAFT ROTATION -----
 INLET PORT ORIENTATION -----
 OUTLET PORT ORIENTATION -----
 INLET ADAPTER OPTION -----
 OUTLET ADAPTER OPTION -----

MOTOR
 MOTOR MANUFACTURER -----
 TYPE -----
 FRAME -----
 POWER -----
 ROTATING SPEED -----
 PHASE(S) -----
 FREQUENCY -----
 VOLTAGE -----
 CONDUIT BOX POSITION -----
 MOTOR INSTALLED BY -----

CERTIFIED BY -----

IMO ORDER NUMBER -----

CERTIFICATION DATE -----

CERTIFICATION REV. NO. -----

NOTES:

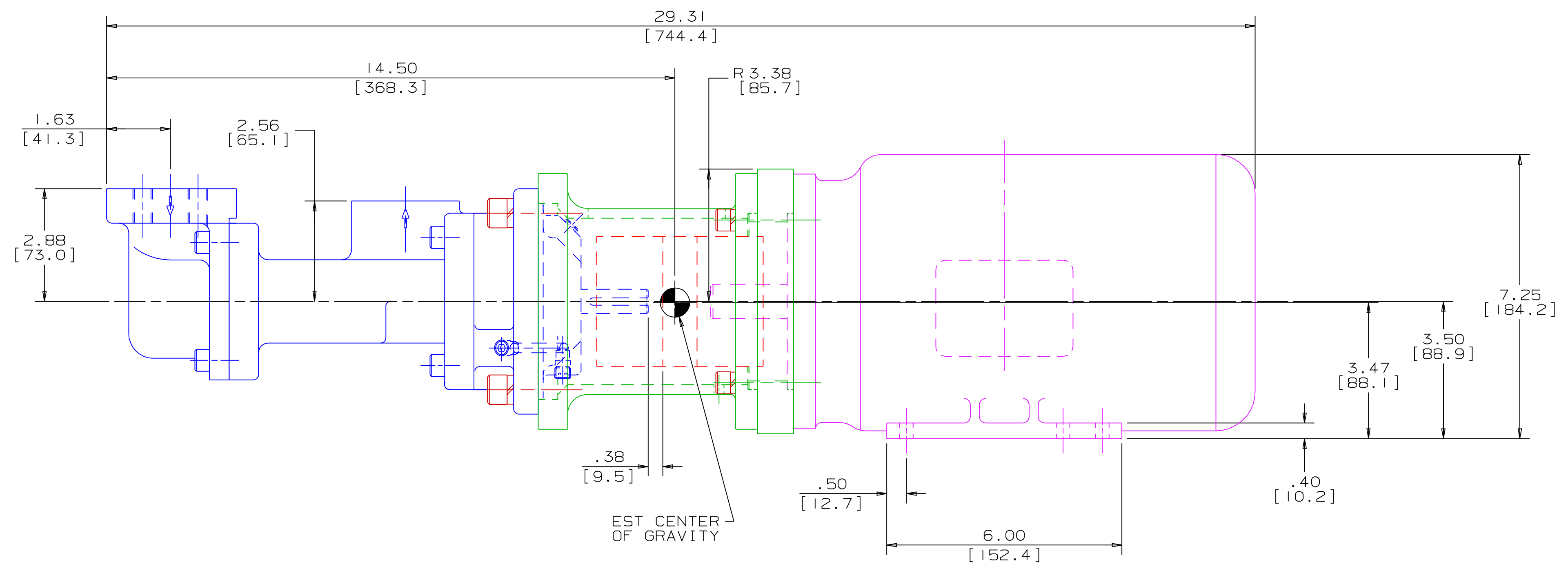

← ROTATION →

- NOTES:
- UNLESS OTHERWISE SPECIFIED, ALL DIMENSIONS ARE IN INCHES. DIMENSIONS IN [] ARE MILLIMETERS.
 - THIS IS A STANDARD PRE-ENGINEERED UNIT OUTLINE. ANY CHANGES OUTSIDE OF THE CERTIFICATION BLOCK WILL REQUIRE A NEW DRAWING ASSIGNMENT.
 - APPROXIMATE WEIGHT AND ESTIMATED C/G DO NOT INCLUDE OPTIONAL ADAPTERS OR OPTIONAL RELIEF VALVE.
 - TO MAXIMIZE SEAL LIFE, SEAL VENT MUST BE ORIENTED UPWARD (12 O'CLOCK) WHEN PUMP IS INSTALLED HORIZONTALLY. VENT ORIENTATION IS NOT CRITICAL WHEN PUMP IS INSTALLED WITH SHAFT VERTICALLY UPWARD.
 - ALTERNATE PORT ORIENTATIONS ARE PROVIDED IF SPECIFIED ON ORDER. AVAILABLE ORIENTATIONS ARE 3,6,9, AND 12 O'CLOCK.

WEB ADDRESS: WWW. IMO-PUMP.COM EMAIL: IMO.PUMP@COLFAXCORP.COM

DRAWN DMM 7-28-01

CHECKED DMM 9-24-01

APPD DMM 9-24-01

METHODS

PROCESS

COMMENTS:
 STANDARD ROTATION IS CLOCKWISE WHEN VIEWED FROM COUPLING END OF PUMP. SUCTION STRAINER AND DISCHARGE RELIEF VALVE MUST BE PROVIDED.
 UNITS ARE ACCURATELY ALIGNED AT THE FACTORY. ALIGNMENT SHOULD BE CHECKED BEFORE STARTING TO ENSURE THAT IT IS STILL WITHIN .005 [0.13] FTW.
 PREPARE SIGHT PIPING BEFORE CONNECTING PUMP. PRIME AND VENT PUMP. DO NOT START PUMP WITH VALVES CLOSED. READ INSTRUCTION MANUAL FOR DETAILS BEFORE STARTING.

TITLE
 OUTLINE UNIT STANDARD (STEEL)
 AA3G / S 118

SIZE
 59180 SDD20090

SCALE
 1/2

WEIGHT
 SEE ABOVE

SHEET
 1 OF 1

STEEL 3G-118 UNIT