

REVISION HISTORY					
CHG NO	ZONE	REV	DESCRIPTION	DATE	BY / APPROVED

ITEM	DESCRIPTION	APPROXIMATE WEIGHT		MATERIAL
		LBS	KG	
1	MOTOR • (1B2TC & 1B4TC)	125.0	56.7	
2	PUMP	44.0	20.0	
3	COUPLING, LOVEJOY L-110	6.0	2.7	
4	BRACKET	4.5	2.0	ALUMINUM
TOTAL		179.5	81.4	

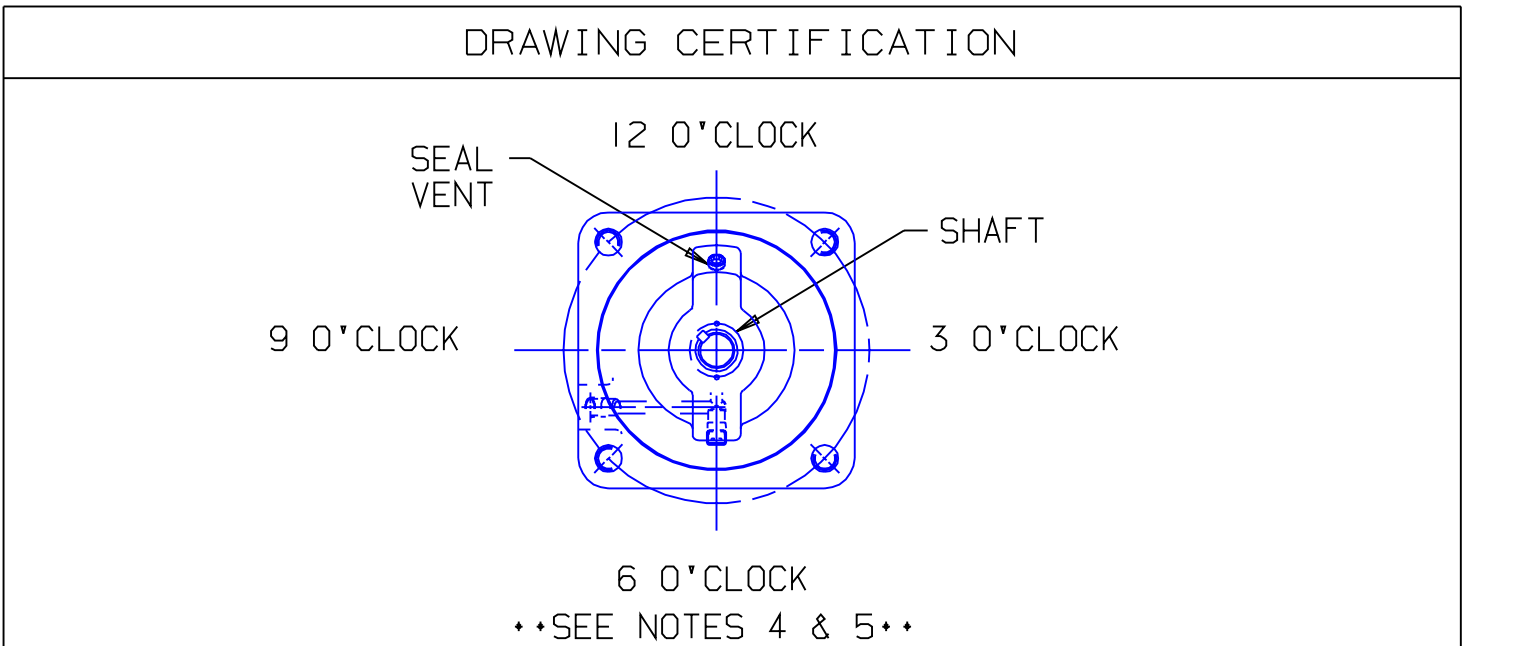

CUSTOMER NAME	-----
CUSTOMER PO NUMBER	-----
CUSTOMER PART NUMBER	-----
UNIT BOM NUMBER	-----
PUMP TYPE	-----
SHAFT ROTATION	-----
INLET PORT OPTION	-----
OUTLET PORT OPTION	-----
INLET PORT ORIENTATION	-----
OUTLET PORT ORIENTATION	-----
INLET ADAPTER OPTION	-----
OUTLET ADAPTER OPTION	-----
RELIEF VALVE SET PRESSURE, IF APPLICABLE	-----
MOTOR MANUFACTURER	-----
TYPE	-----
FRAME	-----
POWER	-----
ROTATING SPEED	-----
PHASE(S)	-----
FREQUENCY	-----
VOLTAGE	-----
CONDUIT BOX POSITION	-----
MOTOR INSTALLED BY	-----
CERTIFIED BY	-----
IMO ORDER NUMBER	-----
CERTIFICATION DATE	-----
CERTIFICATION REV. NO.	-----

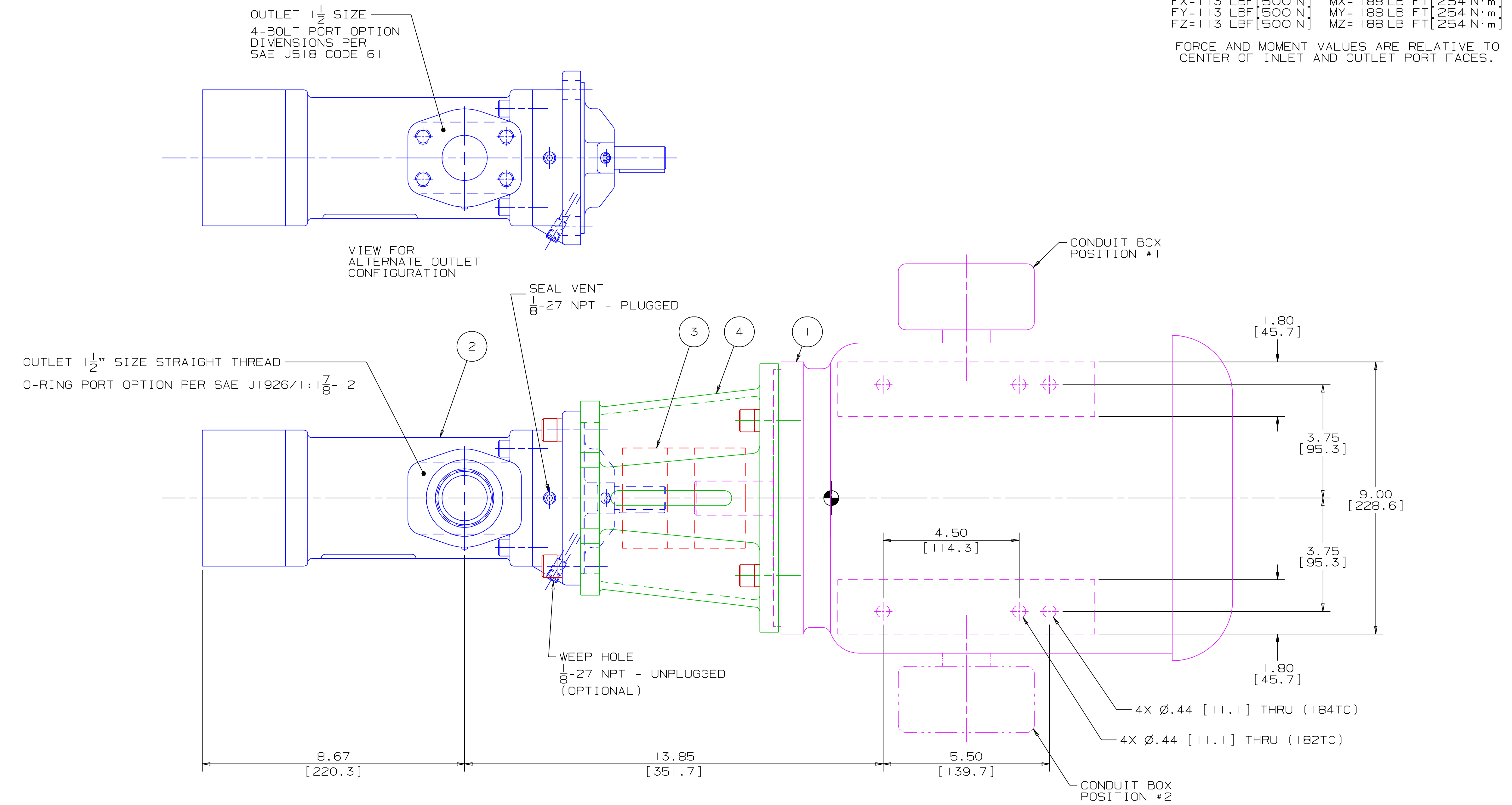
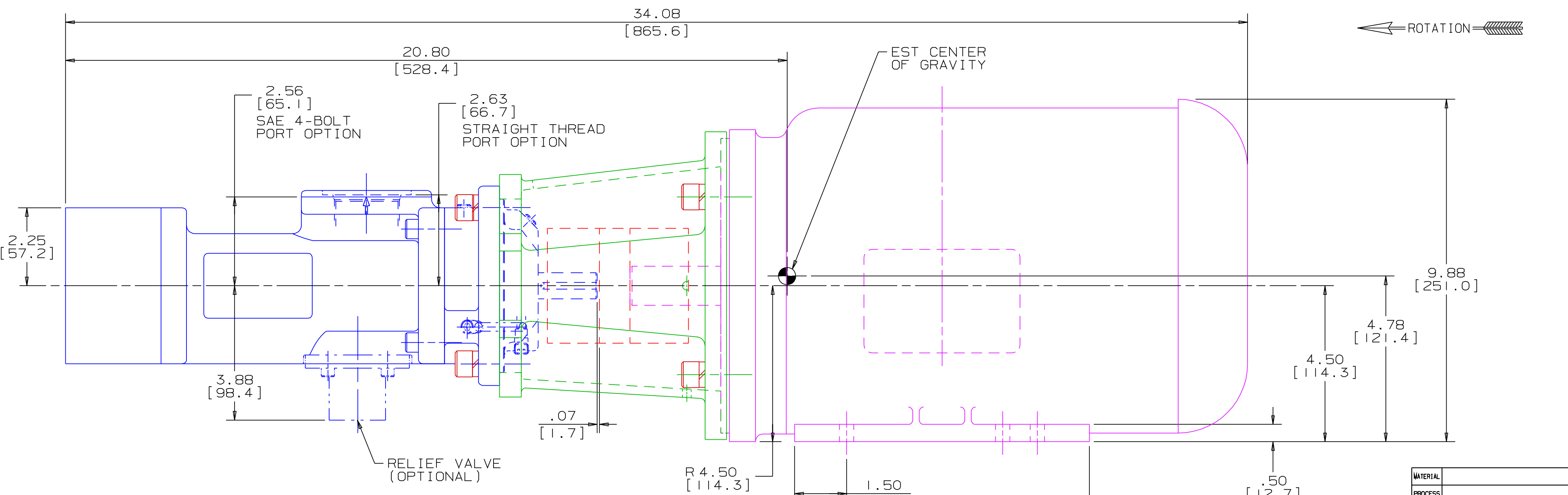
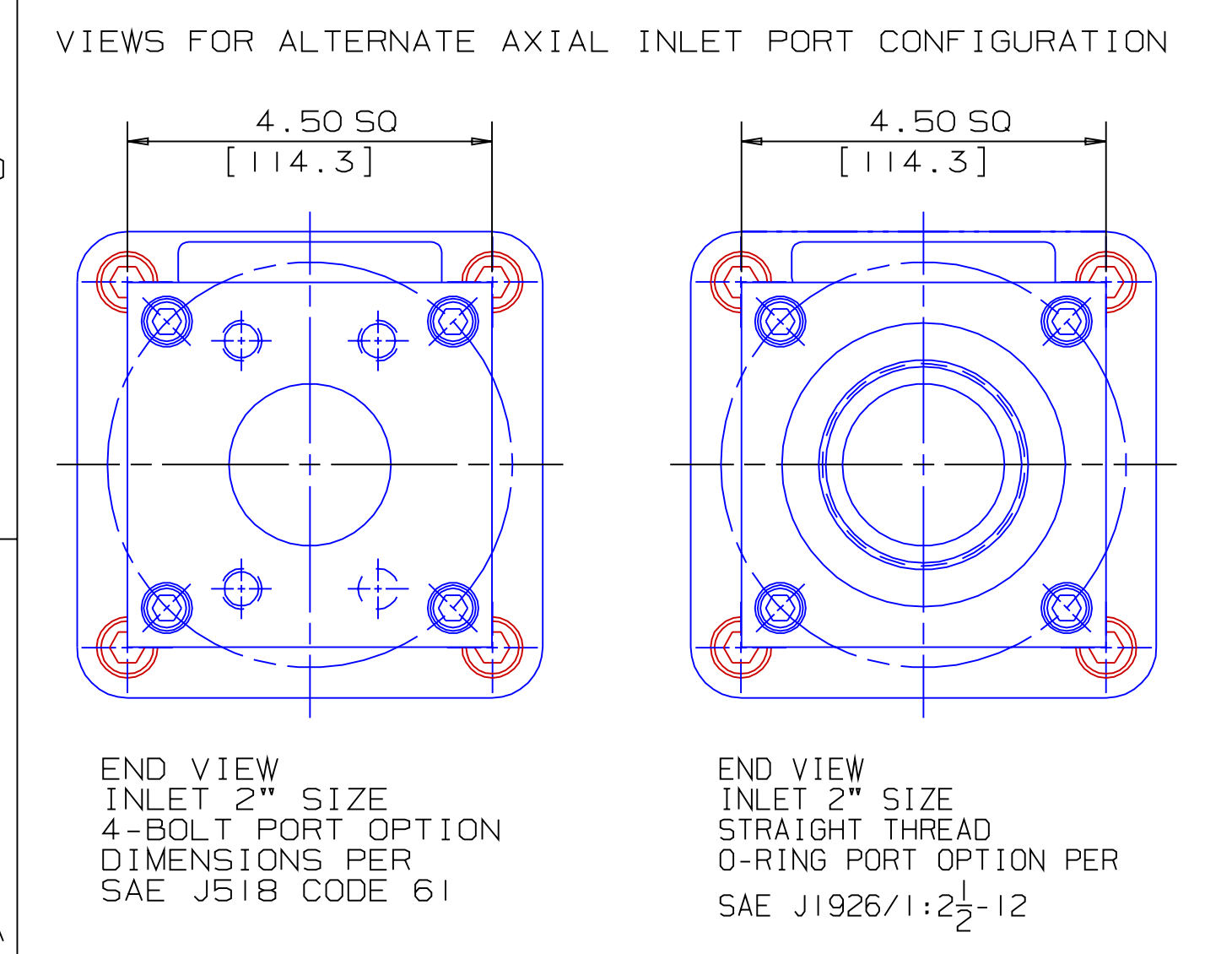

- NOTES:
- UNLESS OTHERWISE SPECIFIED, ALL DIMENSIONS ARE IN INCHES. DIMENSIONS IN [] ARE MILLIMETERS.
 - THIS IS A STANDARD PRE-ENGINEERED UNIT OUTLINE. ANY CHANGES OUTSIDE OF THE CERTIFICATION BLOCK WILL REQUIRE A NEW DRAWING ASSIGNMENT.
 - APPROXIMATE WEIGHT AND ESTIMATED C/G DO NOT INCLUDE OPTIONAL ADAPTERS OR OPTIONAL RELIEF VALVE.
 - TO MAXIMIZE SEAL LIFE, SEAL VENT MUST BE ORIENTED UPWARD (12 O'CLOCK) WHEN PUMP IS INSTALLED HORIZONTALLY. VENT ORIENTATION IS NOT CRITICAL WHEN PUMP IS INSTALLED WITH SHAFT VERTICALLY UPWARD.
 - ALTERNATE PORT ORIENTATIONS ARE PROVIDED IF SPECIFIED ON ORDER. AVAILABLE ORIENTATIONS ARE 3,6,9, AND 12 O'CLOCK.

WEB ADDRESS: WWW.IMO-PUMP.COM		EMAIL: IMO.PUMP@COLFAXCORP.COM	
DRAWN	DMM 9-13-01	<p>IMO Pump 1710 Airport Road PO Box 5020 Monroe, NC USA 28111.5020</p>	<p>TITLE OUTLINE UNIT STANDARD (IRON) AA3G / 143 / 162</p>
CHECKED	DMM 10-5-01		
APPROD	DMM 10-5-01		
METHODS			
PROCESS		<p>COMMENTS: STANDARD ROTATION IS CLOCKWISE WHEN VIEWED FROM COUPLING END OF PUMP. SUCTION STRAINER AND DISCHARGE RELIEF VALVE MUST BE PROVIDED. UNITS ARE ACCURATELY ALIGNED AT THE FACTORY. ALIGNMENT SHOULD BE CHECKED BEFORE STARTING TO ENSURE THAT IT IS STILL WITHIN .005 [0.13] F.T.M. FLUSH SUCTION PIPING BEFORE CONNECTING PUMP. PRIME AND VENT PUMP. DO NOT START PUMP WITH VALVES CLOSED. READ INSTRUCTION MANUAL FOR DETAILS BEFORE STARTING.</p>	<p>SCALE 1/2</p> <p>WEIGHT SEE ABOVE</p> <p>SHEET 1 OF 1</p>

IRON 3G-143/162 UNIT