

INLET:  
 FX=113 LBF [500 N]    MY=188 LB FT [254 N·m]  
 FY=113 LBF [500 N]    MZ=188 LB FT [254 N·m]  
 FZ=113 LBF [500 N]

OUTLET:  
 MX=125 LB FT [169 N·m]  
 MY=125 LB FT [169 N·m]  
 MZ=125 LB FT [169 N·m]  
 FX=75 LBF [334 N]  
 FY=75 LBF [334 N]  
 FZ=75 LBF [334 N]

FORCE AND MOMENT VALUES ARE RELATIVE TO CENTER OF INLET AND OUTLET PORT FACES.

REVISION HISTORY					
CHG NO	ZONE	REV	DESCRIPTION	DATE	BY / APPROVED

ITEM	DESCRIPTION	APPROXIMATE WEIGHT		MATERIAL
		LBS	KG	
1	MOTOR * (213TC & 215TC)	190.0	86.2	
2	PUMP	34.0	15.4	
3	COUPLING, LOVEJOY L-110	6.0	2.7	
4	BRACKET	5.0	2.3	ALUMINUM
TOTAL		235.0	106.6	

\* DRIVER DIMENSIONS MAY VARY WITH TYPE AND MAKE OF DRIVER

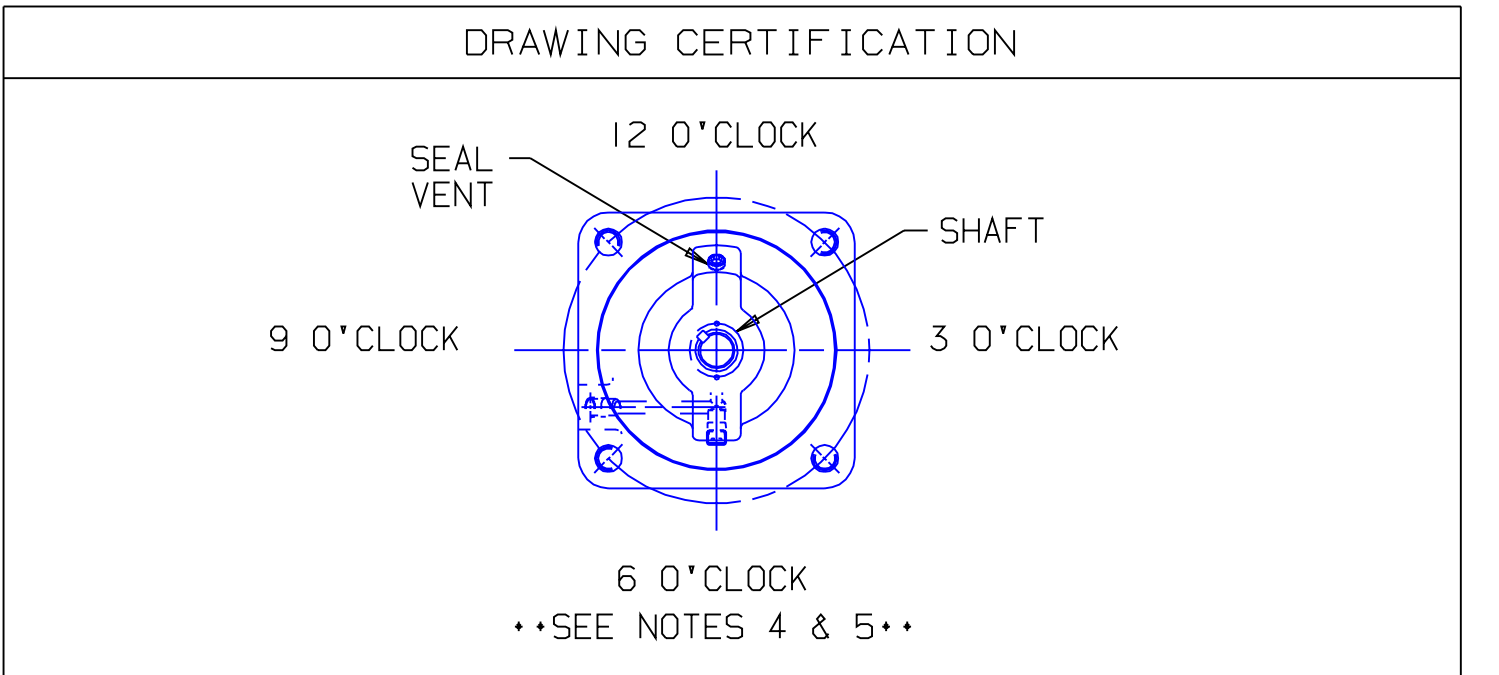
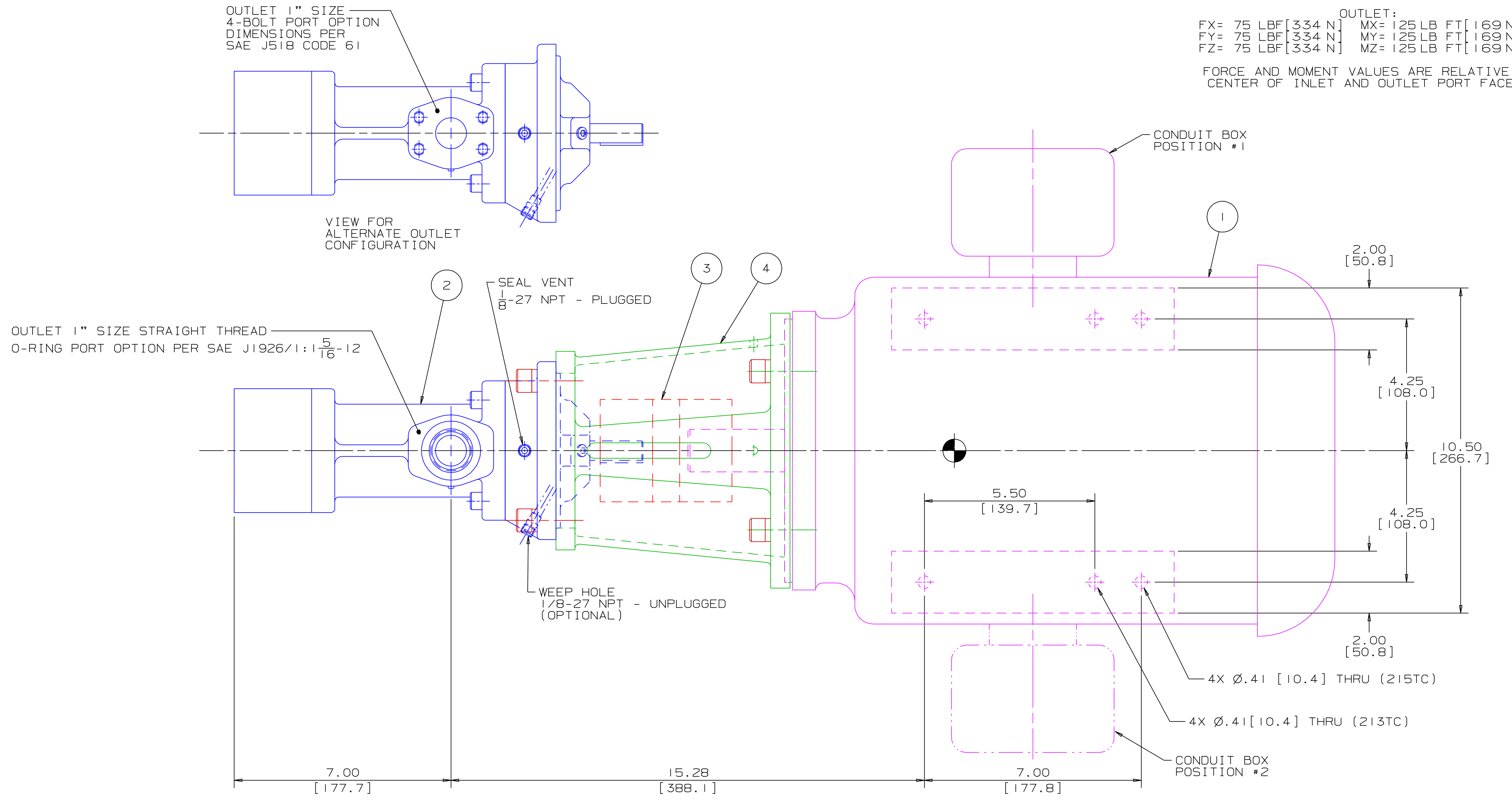

CUSTOMER NAME -----

CUSTOMER PO NUMBER -----

CUSTOMER PART NUMBER -----

UNIT BOM NUMBER -----

PUMP

PUMP TYPE -----

SHAFT ROTATION -----

INLET PORT OPTION -----

OUTLET PORT OPTION -----

INLET PORT ORIENTATION -----

OUTLET PORT ORIENTATION -----

INLET ADAPTER OPTION -----

OUTLET ADAPTER OPTION -----

RELIEF VALVE SET PRESSURE, IF APPLICABLE -----

MOTOR

MOTOR MANUFACTURER -----

TYPE -----

FRAME -----

POWER -----

ROTATING SPEED -----

PHASE(S) -----

FREQUENCY -----

VOLTAGE -----

CONDUIT BOX POSITION -----

MOTOR INSTALLED BY -----

CERTIFIED BY -----

IMO ORDER NUMBER -----

CERTIFICATION DATE -----

CERTIFICATION REV. NO. -----

NOTES:

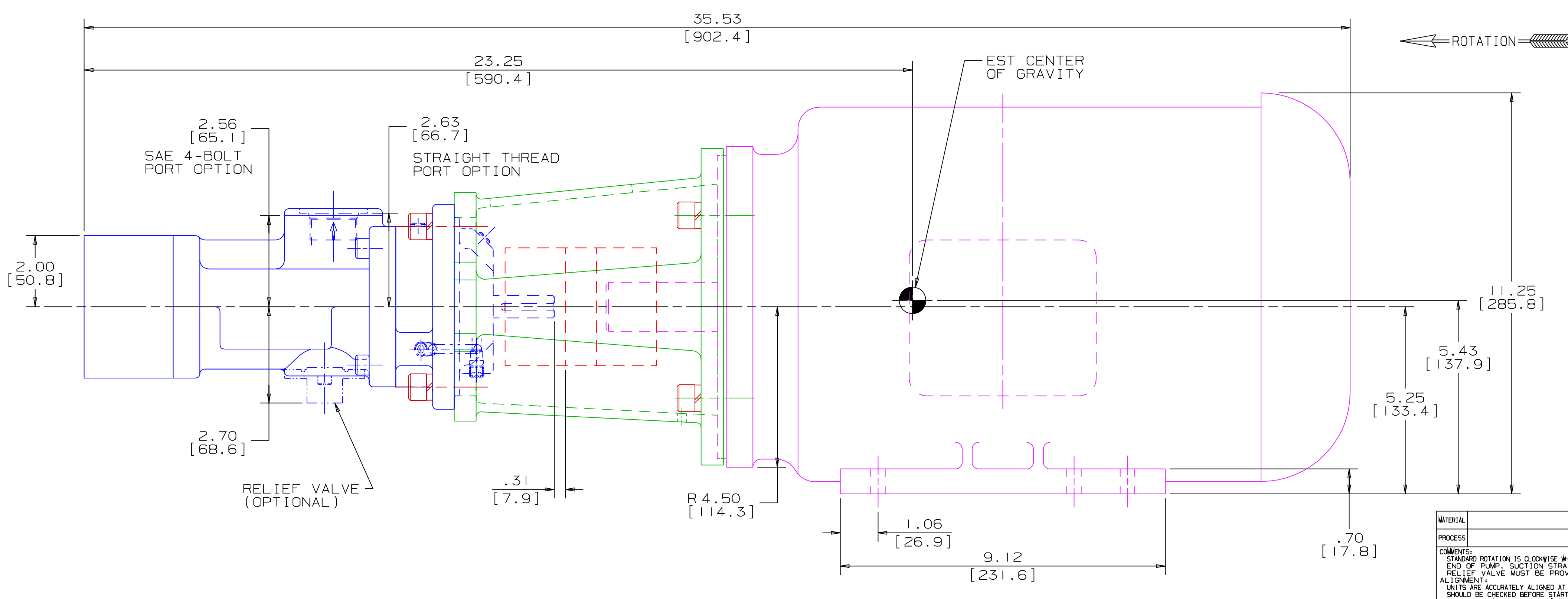
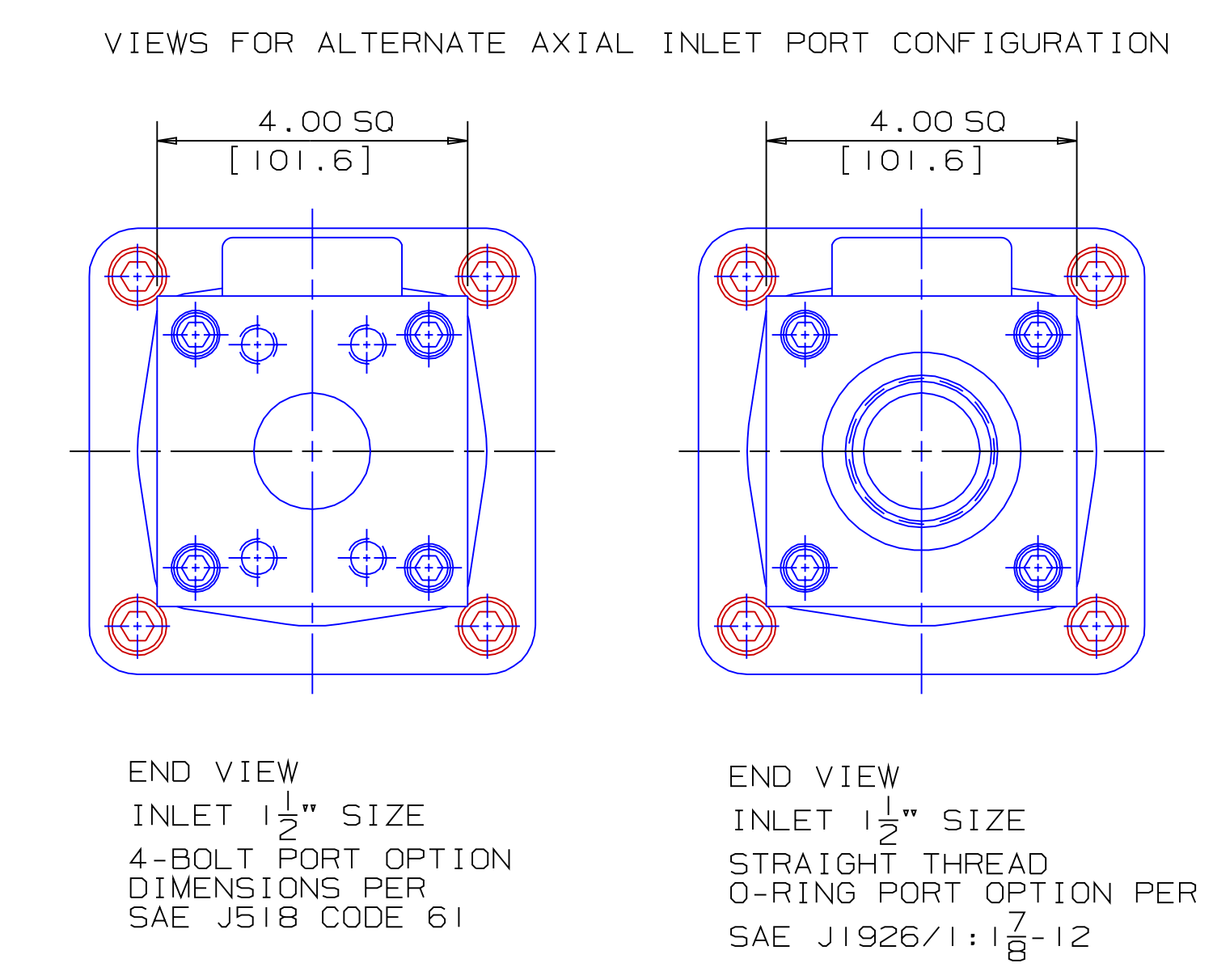

- NOTES:
- UNLESS OTHERWISE SPECIFIED, ALL DIMENSIONS ARE IN INCHES. DIMENSIONS IN [ ] ARE MILLIMETERS.
  - THIS IS A STANDARD PRE-ENGINEERED UNIT OUTLINE. ANY CHANGES OUTSIDE OF THE CERTIFICATION BLOCK WILL REQUIRE A NEW DRAWING ASSIGNMENT.
  - APPROXIMATE WEIGHT AND ESTIMATED C/G DO NOT INCLUDE OPTIONAL ADAPTERS OR OPTIONAL RELIEF VALVE.
  - TO MAXIMIZE SEAL LIFE, SEAL VENT MUST BE ORIENTED UPWARD (12 O'CLOCK) WHEN PUMP IS INSTALLED HORIZONTALLY. VENT ORIENTATION IS NOT CRITICAL WHEN PUMP IS INSTALLED WITH SHAFT VERTICALLY UPWARD.
  - ALTERNATE PORT ORIENTATIONS ARE PROVIDED IF SPECIFIED ON ORDER. AVAILABLE ORIENTATIONS ARE 3,6,9, AND 12 O'CLOCK.

WEB ADDRESS: WWW. IMO-PUMP.COM    EMAIL: IMO.PUMP@COLFAXCORP.COM

DRAWN DMM 9-18-01

CHECKED DMM 10-4-01

APPD DMM 10-4-01

METHODS

PROCESS

COMMENTS: STANDARD ROTATION IS CLOCKWISE WHEN VIEWED FROM COUPLING END OF PUMP. SUCTION STRAINER AND DISCHARGE RELIEF VALVE MUST BE PROVIDED. UNITS ARE ACCURATELY ALIGNED AT THE FACTORY. ALIGNMENT SHOULD BE CHECKED BEFORE STARTING TO ENSURE THAT IT IS STILL WITHIN .005 [0.13] F.T.M. FLASH SECTION BEFORE CONNECTING PUMP. PRIME AND VENT PUMP. DO NOT START PUMP WITH VALVES CLOSED. READ INSTRUCTION MANUAL FOR DETAILS BEFORE STARTING.

SCALE 1/2

WEIGHT SEE ABOVE

SHEET 1 OF 1

IMO Pump  
 1710 Airport Road  
 PO Box 5020  
 Monroe, NC USA  
 28111.5020

TITLE  
 OUTLINE UNIT STANDARD (IRON)  
 AA3G / 118

SIZE CAGE CODE DWG NO  
 F 59180 SDD 19832

IRON 3G-118 UNIT