

REVISION HISTORY						
CHG NO	ZONE	REV	DESCRIPTION	DATE	BY	APPROVED
00-0579	ALL	2	UPDATED TO CURRENT STANDARDS	9-15-00	DMM	DMM

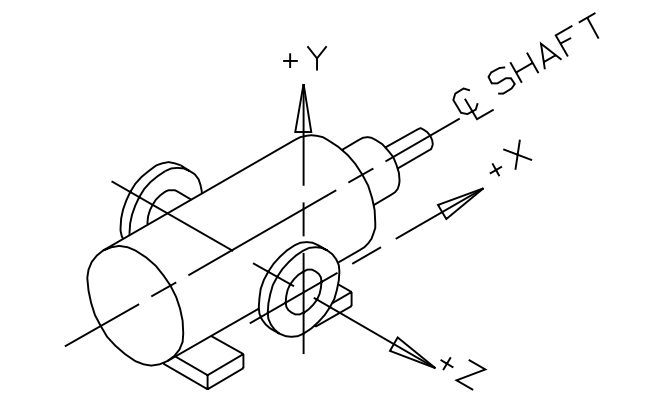
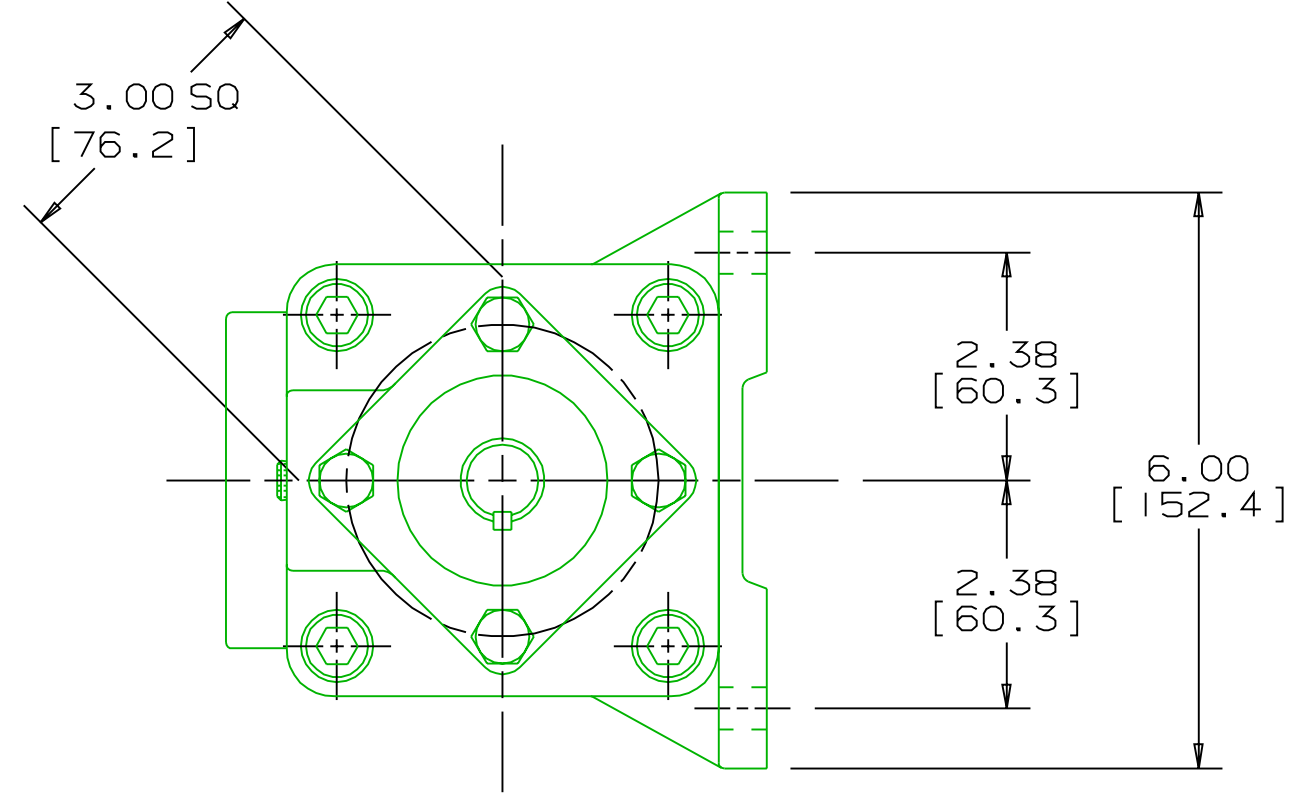
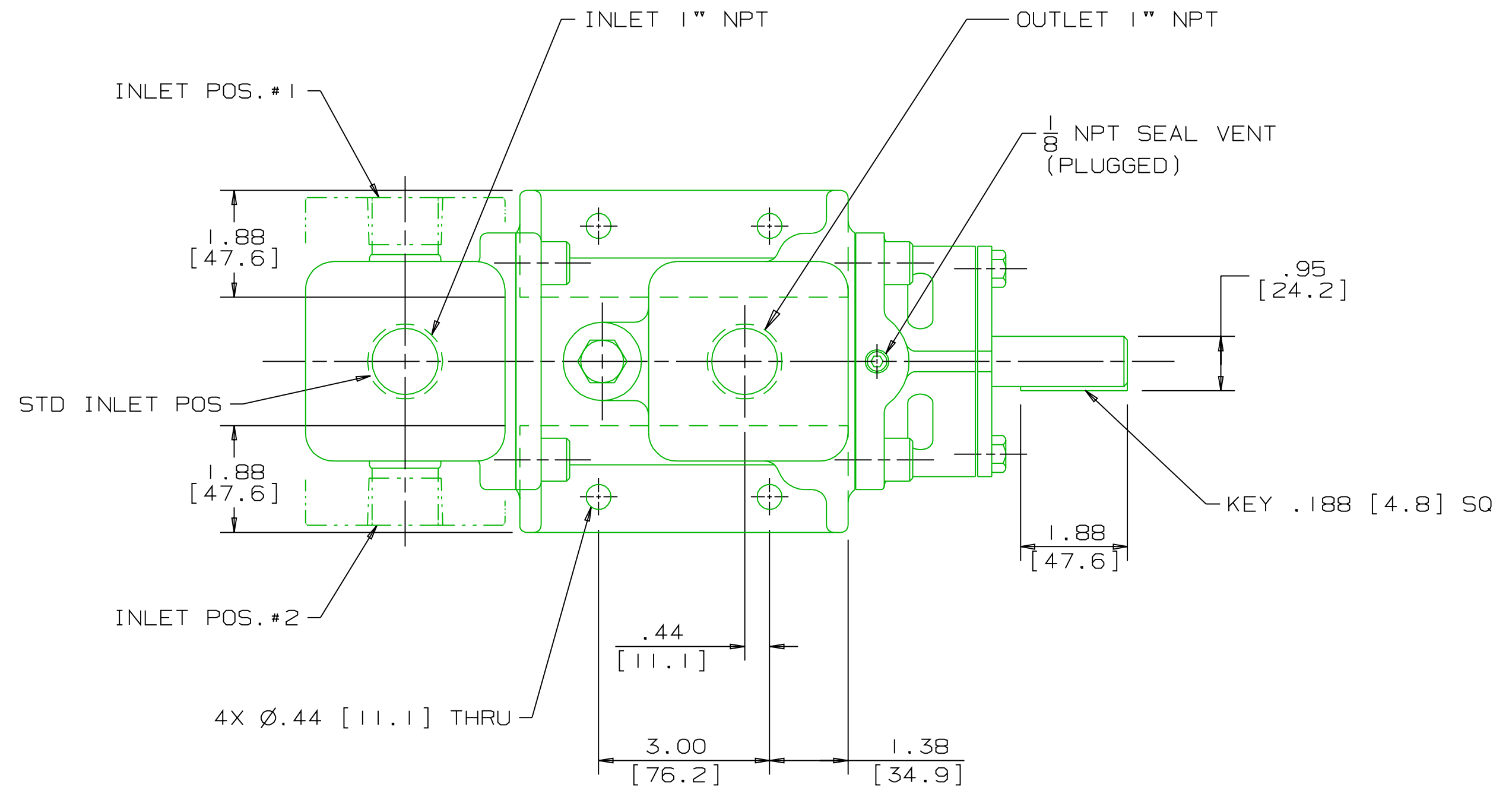

COORDINATE SYSTEM FOR MAXIMUM PUMP FORCES (F) AND MOMENTS (M)

INLET:  
 FX=75 LBF [334 N]    MX=125 LB FT [169 N·m]  
 FY=75 LBF [334 N]    MY=125 LB FT [169 N·m]  
 FZ=75 LBF [334 N]    MZ=125 LB FT [169 N·m]

OUTLET:  
 FX=75 LBF [334 N]    MX=125 LB FT [169 N·m]  
 FY=75 LBF [334 N]    MY=125 LB FT [169 N·m]  
 FZ=75 LBF [334 N]    MZ=125 LB FT [169 N·m]

FORCE AND MOMENT VALUES ARE RELATIVE TO CENTER OF INLET AND OUTLET PORT FACES.

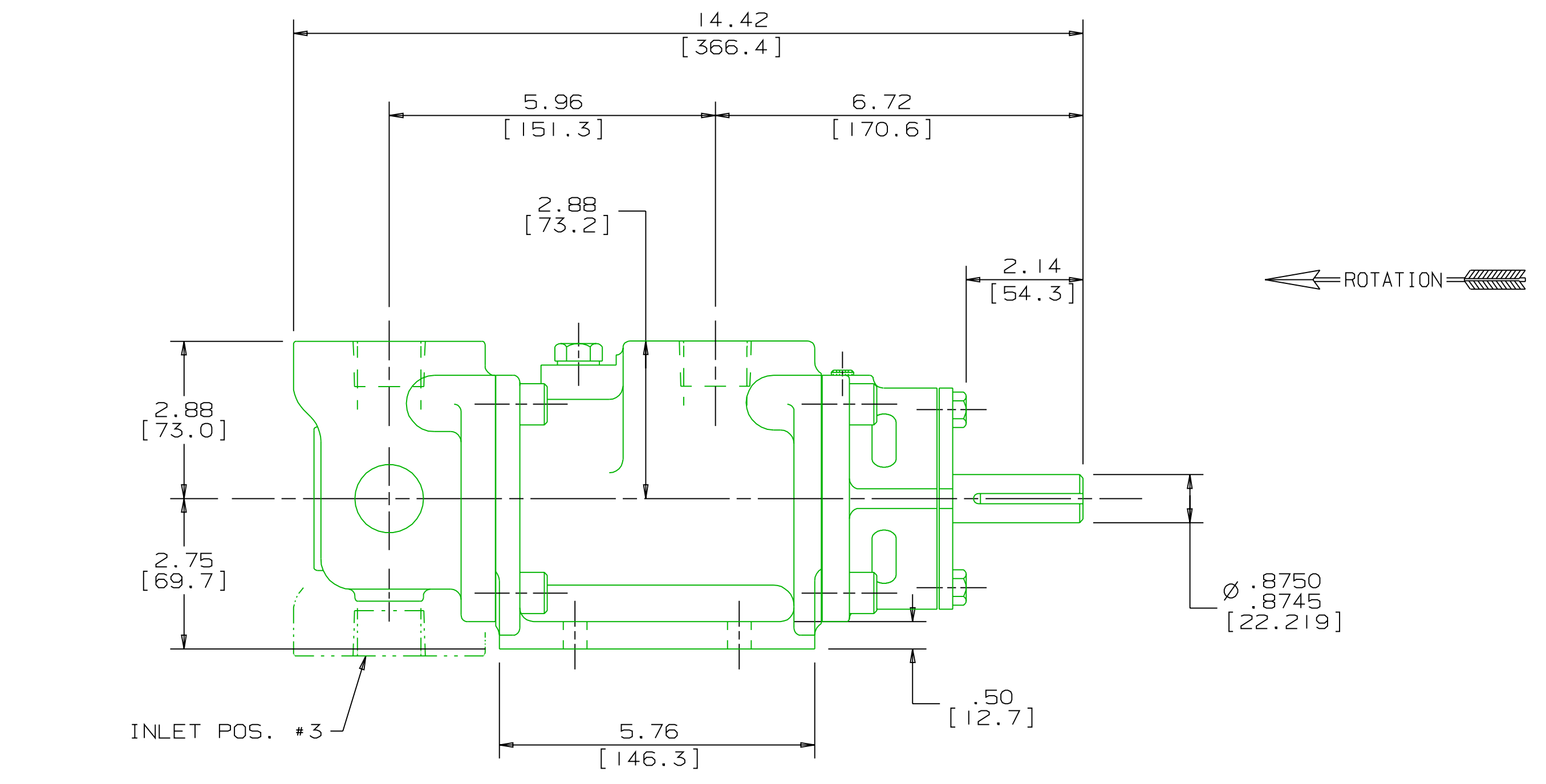

- NOTES:
- UNLESS OTHERWISE SPECIFIED, ALL DIMENSIONS ARE IN INCHES. DIMENSIONS IN [ ] ARE MILLIMETERS.
  - TO MAXIMIZE SEAL LIFE, SEAL VENT MUST BE ORIENTED UPWARD (12 O'CLOCK) WHEN PUMP IS INSTALLED HORIZONTALLY. THIS IS NORMAL VENT ORIENTATION WHEN PUMP FEET ARE ORIENTED DOWNWARD. SEAL VENT ORIENTATION IS NOT CRITICAL WHEN PUMP IS INSTALLED WITH SHAFT VERTICALLY UPWARD.
  - PORT, FOOT, AND SEAL VENT ORIENTATIONS ARE SUPPLIED AS SHOWN ON DRAWING UNLESS OTHERWISE SPECIFIED.
  - ALTERNATE INLET PORT POSITIONS ARE PROVIDED IF SPECIFIED ON ORDER. AVAILABLE POSITIONS ARE: STANDARD, POSITION #1, POSITION #2 OR POSITION #3. ALL INLET PORT POSITIONS ARE RELATIVE TO OUTLET PORT.
  - ESTIMATED WEIGHT 41 LBS [18.6 kg].

DRAWING CERTIFICATION	
CUSTOMER NAME	-----
CUSTOMER PO NUMBER	-----
CUSTOMER PART NUMBER	-----
BOM NUMBER	-----
PUMP TYPE	-----
SHAFT ROTATION	-----
INLET PORT POSITION	-----
OTHER INFORMATION	
CERTIFIED BY	-----
CERTIFIED DATE	-----
IMO ORDER NUMBER	-----
DATA REVISION NUMBER	-----

WEB ADDRESS: WWW.IMO-PUMP.COM    EMAIL: IMO.PUMP@COLFAXCORP.COM

DRAWN: WLW 5-23-95  
 CHECKED: MJC 5-30-95  
 APP'D: MJC 5-30-95

**Imo Pump**  
 1710 Airport Road  
 PO Box 5020  
 Monroe, NC USA  
 28111.5020

TITLE: OUTLINE STANDARD \_\_\_3D\_\_\_-106\_\_

THIRD ANGLE PROJECTION    F FIRST ORDER    SIZE: D    CAGE CODE: 59180    DWG NO: SDD18295

USED ON: 3201/112    SCALE: 1/2    WEIGHT: SEE NOTE 5    SHEET: 1 OF 1

MATERIAL: \_\_\_\_\_  
 PROCESS: \_\_\_\_\_  
 COMMENTS:  
 STANDARD ROTATION IS CLOCKWISE WHEN VIEWED FROM COUPLING END OF PUMP. SUCTION STRAINER AND DISCHARGE RELIEF VALVE MUST BE PROVIDED.  
 ALIGNMENT:  
 UNITS ARE ACCURATELY ALIGNED AT THE FACTORY. ALIGNMENT SHOULD BE CHECKED BEFORE STARTING TO ENSURE THAT IT IS STILL WITHIN .005 [0.13] F.W.  
 PRESTARTING:  
 FLUSH SUCTION PIPING BEFORE CONNECTING PUMP. PRIME AND VENT PUMP. DO NOT START PUMP WITH VALVES CLOSED. READ INSTRUCTION MANUAL FOR DETAILS BEFORE STARTING.