



INSTRUCTIONS and PARTS LIST

SERIES FPG12LZ-250

WARNING

**READ THIS INSTRUCTION BOOK AND CA-1 BEFORE
INSTALLATION, OPERATION OR MAINTENANCE**

Instructions FPG12L (R-2)

This manual now is
identified as part no.
SRM00058

ORDERING INSTRUCTIONS

All correspondence pertaining to renewal parts for the equipment must refer to the instruction book number and should be addressed to the nearest Imo Pump Division Sales Office or representative. See addresses of sales offices listed above.

The handling of renewal orders will be greatly facilitated if the following directions are carefully observed.

1. Give the number of the instruction book.
2. Give the serial number of the machine for which part is desired. This number appears on the name-plate.
3. Designate the desired part by the number and name as listed in this instruction book.
4. Give the drawing number or figure number in which the part is shown. (In the event the part is called out on an unnumbered sketch – the page number on which the sketch appears should be used in lieu of the drawing number as the reference.)

For Example:

Instruction Book No.A3D-6
Serial Number505629
Part Number and Name063, Power Rotor
Drawing Number (see item 4 above)SF-5377

FOREWORD

This manual covers the FPG12LZ-250 Series IMO pump. The model of a particular pump may be found on the nameplate.

The FPG12LZ-250 series pumps are equipped with a steel case and rotors, bimetallic housing, high temperature ball bearing and a Borg-Warner Type Q mechanical shaft seal.

SPECIAL INSTALLATION INSTRUCTIONS

Mounting

Driver - The unit may be mounted in any position without adversely affecting its performance. It is recommended that the unit be driven direct through a flexible coupling.

Inlet Position - The inlet head may be positioned in increments of 90° from the position shown on the assembly drawing.

Remove cap screws and rotate inlet head to desired position. Replace cap screws and torque to value listed on appropriate assembly drawing.

OPERATIONAL SAFETY PRECAUTIONS

Structural Limits

Operating conditions, such as speed, fluid viscosity, inlet pressure, discharge pressure, temperature, filtration, duty cycle, mounting, drive type, etc. are interrelated. Due to these variable conditions, the specific application limitations may be different from that of the structural limitations. This equipment must not be operated without verification that operating requirements are within published capabilities as shown in the appropriate pump data book (available from local IMO Pump Division offices and representatives).

Under no circumstances are the following structural limitations to be exceeded.

Maximum Discharge Pressure - 1100 PSIG Normal - 1400 PSIG Fuel Oil - 3000 PSIG Lube Oil

Maximum Inlet Pressure - 75 PSIG

Maximum Speed - 3600 RPM

Disassembly of Pump

General - Close off suction and discharge piping to pump. Disconnect piping and uncouple pump from its driver. To keep spillage to a minimum during disassembly, drain the pump case. This may be accomplished by removing the drain plug (041) from the inlet head (040).

Step 1 – Remove pump from its base to a convenient and clean working area.

Step 2 – Loosen set screw (045), remove check nut (044), key (043), and the coupling hub from power rotor (018).

Step 3 – Remove cap screws (028) and retainer (027).

Step 4 – Pull power rotor assembly from cover (013). The power rotor assembly consists of parts—power rotor (018), mechanical seal (019), gasket (020), adapter seat (022), pin (023), spacer (024), bearing (026), and truarc retaining rings (025).

CAUTION

Gasket (020) may be on the adapter seat (022) or the inboard end cover (013).

Step 5 – Remove inlet head (040) by removing (12) cap screws (030), gasket (011), clamp ring (047), and pin (048).

Step 6 – Remove cover inboard assembly by removing (12) cap screws (030). The inboard cover assembly consists of inboard cover (013), stop (016), two cap screws (017), "O" ring (010), spring pin (014), and bushing (015). Gasket (029) will be on cover (013) or case (001).

Step 7 – Remove two idler rotors (034) and two idler rotor assemblies (031). Idler rotor assembly (031) consists of idler rotor (032) and shoe (033).

Step 8 – Rotor housing assembly can now be removed from the inlet end of the pump. The rotor housing assembly consists of rotor housings (005) and (008), two vent pins (007), spring pin (006), adjusting cap screws (009), two cap screws (039), plate (035), thrust plate (036), two cap screws (037), two spacers (038), and "O" ring (010).

Step 9 – Remove thrust assembly by removing two cap screws (039), two spacers (038), and two cap screws (037) from plate (036).

Step 10 – Remove bushing (015) by removing two cap screws (017), and stop (016) from inboard end cover (013).

Step 11 – To remove the mechanical seal (019) from power rotor (018), remove retaining ring (025) nearest the keyway and remove ball bearing (026) and spacer (024).

Step 12 – Remove retaining ring (025) nearest the mechanical seal, then remove the adapter seat assembly consisting of the seat adapter (022), pin (023), stationary seat, and its "O" ring. Remove the mechanical seal from power rotor (018).

Reassembly of Pump

Inspect and clean all parts before starting reassembly. New "O" rings should be installed whenever the pump is rebuilt.

NOTE: All screws and bolts must be installed lubricated with oil and torqued to the values listed on the appropriate assembly drawing. Light lubricating oil should be used to assist pump reassembly. **DO NOT USE GREASE.**

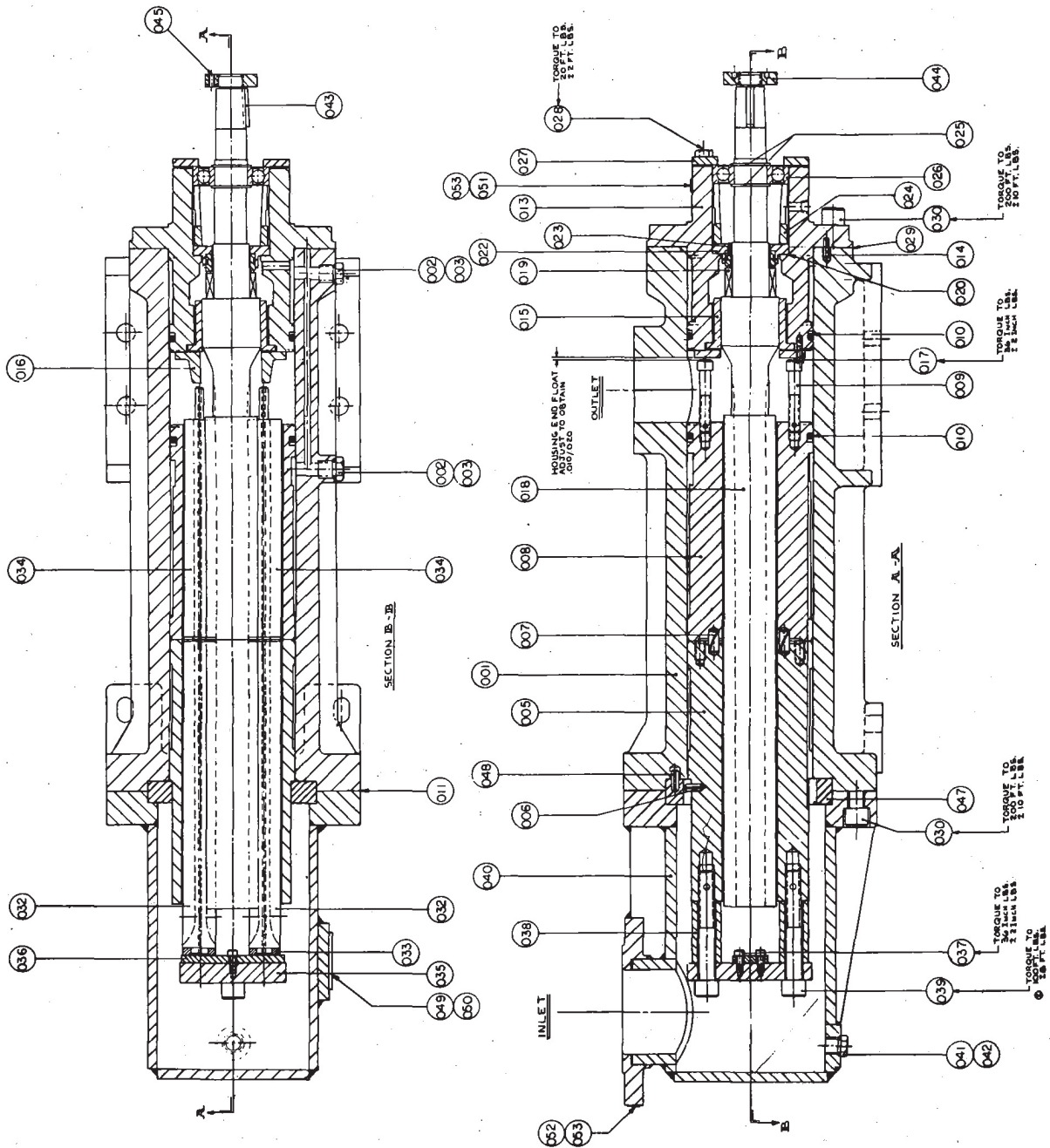

NOTES:
 1 FOR PART DESCRIPTION SEE STD. OR PURPOSE BILL OF MATERIAL PART NUMBERS OR BILL OF MATERIAL NUMBERS SHOWN
 2 ALL BOLTS TO BE INSTALLED LUBRICATED WITH OIL

FPG 12LZ-250

- c. Insert two idler rotor assemblies, consisting of idler rotor (032) and shoe (033), the shoe end first to ride against the thrust plate (036).
- d. Insert two idler rotors (034) into rotor (008) tubular extensions toward the outlet port.

Step 7 - End Cover Assembly (Step 2)

- a. Place gasket (029) on face of end cover assembly (013). Bolt to case (001) using (12) capscrews (030). Torque to 200 ± 10 feet pounds. Be sure spring pin (014) is engaged in hole in case (001). The end float in the rotor housings should be .010" to .020".

Step 8 - Assembly of Power Rotor Assembly (Step 1) to End Cover

- a. Install gasket (020) in counter bore in end cover (013).
- b. Insert threaded end of power rotor (018) into end cover (013). Case must be taken not to move gasket (020).
- c. Engage threads of power rotor (018) and idler rotors (034). Slide power rotor toward the suction end and engage idler rotors (032). Continue to slide power rotor (018) toward suction until the seat adapter (022) contacts the gasket (020).
- d. Install bearing retainer (027) with cap screws (028). Torque cap screws to 20 ± 2 feet pounds.

Step 9 -

- a. Install plug (041) and "O" ring (042) in inlet head (040).
- b. Install coupling hub, key (043), check nut (044), and set screw (045).

PARTS LIST
 FPG12LZ-250
 DWG. SF-5584

Pt. No.	Name	Pt. No.	Name	Pt. No.	Name
001	Pump Case	017	Cap Screw (2)	033	Shoe ****
002	Plug STHH (2)	018	Power Rotor XX	034	Idler Rotor (2) XX
003	"O" Ring (2) X	019	Seal X	035	Plate
004	Housing Sub Assem. XX	020	Gasket X	036	Plate XX
005	Housing *	021	Adapter Seat Sub. Assem.	037	Cap Screw (2)
006	Spring Pin *	022	Adapter Seat ***	038	Spacer (2)
007	Vent Pin (2) *	023	Spring Pin ***	039	Cap Screw (2)
008	Housing *	024	Spacer XX	040	Inlet Head
009	Cap Screw (Adjusting) (2) *	025	Truarc Ring (2) X	041	Plug STHH
010	"O" Ring (2) X	026	Ball Bearing X	042	"O" Ring X
011	Gasket X	027	Retainer	043	Key
012	Cover Inb. Sub. Assem.	028	Bolt (4)	044	Check Nut
013	Cover Inb. **	029	Gasket X	045	St. Screw
014	Spring Pin **	030	Cap Screw (24)	046	Clamp Ring Sub Assem.
015	Bushing XX	031	Idler Rotor Sub Assem. XX	047	Clamp Ring *****
016	Stop XX	032	Idler Rotor ****	048	Spring Pin *****

*Parts make-up housing sub assem. 004

** Parts make-up cover inb. sub assem. 012

*** Parts make-up adapter seat sub assem. 021

**** Parts make-up idler rotor sub assem. 031

***** Parts make-up clamp ring sub assem. 046

All parts marked X make-up a minor repair kit.

All parts marked X and XX make-up a major repair kit.

All quantities are one except when noted in parenthesis.

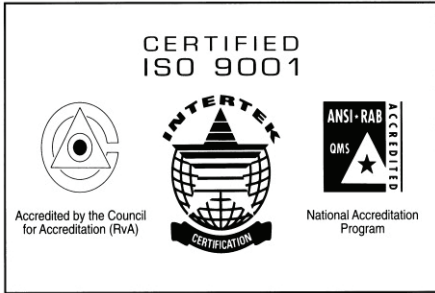

CIRCOR

1710 Airport Road
PO Box 5020
Monroe, NC USA
28111.5020

Tel: +1. 877.853.7867

Email: cc@circor.com

Web: www.circorpt.com

